

1. General Information

- DBT2410a series spring return damper actuator series are designed specifically for applications into the HVAC market.
- DBT high quality damper actuator are developed for use with air damper, butterfly valve, characterized ball valve and other devices that required a fail-safe function.
- The actuator motorized the damper or other devices when power on and spring back to its original position when power is cut off.
- For the operation of air dampers that perform safety functions (e.g. frost and smoke protection, hygiene, etc.). The actuator moves the damper to its normal working position while tensioning the return spring at the same time. If the power supply is interrupted, the damper back to its safe position.



2. Product features

- 2 points on/off control
- Damper size up to 2.0 m²
- Voltage AC/DC 24V and AC 230V available
- Universal Spindle Clamp for easy direct mounting
- Shaft dimension Ø10...16 mm / 7...11 mm square
- Minimum shaft length 40mm
- Anti-rotation bracket provided for stability
- Adjustable angle of rotation
- Selectable direction of rotation by reversing actuator
- 1 adjustable SPDT auxiliary switches when requested
- Energy saving at end stops
- Actuators with 1m cable connection
- Customized version available on request

3. Actuator dimensions (mm)

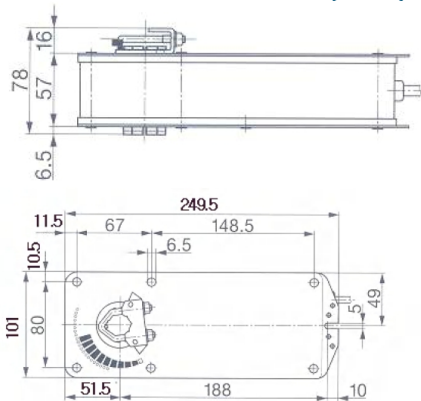

4. Technical specification

	DBT2410a (24V AC/DC)	DBT2310a (230V AC)
Torque motor (rated voltage) spring	10 Nm	10 Nm
Damper size	2 m ²	2 m ²
Power supply	AC/DC 24 V	AC 230 V
Frequency	50 ... 60 Hz	50 ... 60 Hz
Consumption operating	5,0 W	6,5 W
Consumption at the end stops	2,5 W	2,5 W
For wire sizing	10,0 VA	10,0 VA
Auxiliary switched rating (Amp and Voltage)	3 (1,5 A / 230 V (for 24 V and 230 V)	3 (1,5 A / 230 V (for 24 V and 230 V)
Protection class	III (safety low voltage)	II (complete insulation)
Controls signal	2 point, on/off	2 point, on/off
Angle of rotation	90° (95° mechanical)	90° (95° mechanical)
Angle of rotation limiting	5° ... 85° in 5° step	5° ... 85° in 5° step
Weight	2,7 kg	2,7 kg
Life cycle	60.000 rotation	60.000 rotation
Sound level	< 62 dB	< 62 dB
IP Protection class	IP54	IP54
Ambient temperature	-20°C ... +50°C as per IEC 721-3-3	-20°C ... +50°C as per IEC 721-3-3
Ambient humidity	5 ... 95% RH	5 ... 95% RH
Inventory temperature	+70°C as per 721-3-2	+70°C as per 721-3-2
Maintenance	Maintenance free	Maintenance free
Certification	CE	CE

5. Wiring diagram

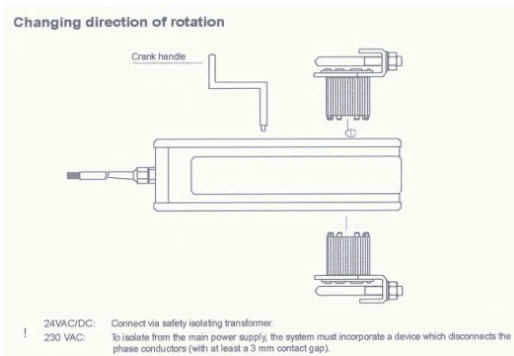
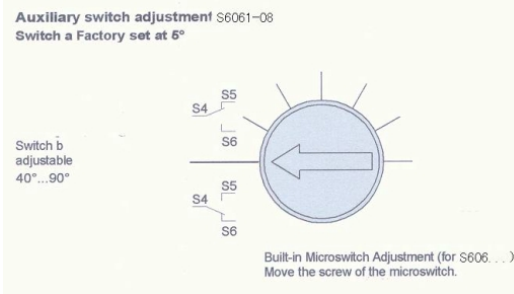
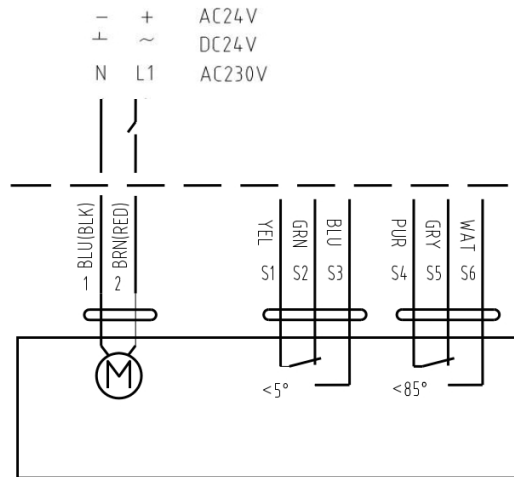

6. Installation / mounting

